

502HO Engine (12568778 Base) Long Block Specifications

Specifications Part Number 19172222

This 502HO long block specification sheet should be used in conjunction with the 502 short block specification sheet, GM part number 19171883

Thank you for choosing GM Performance Parts as your high performance source. GM Performance Parts is committed to providing proven, innovative performance technology that is truly.... more than just power. GM Performance Parts are engineered, developed and tested to exceed your expectations for fit and function. Please refer to our catalog for the GM Performance Parts Authorized Center nearest you or visit our website at www.gmperformanceparts.com.

This publication provides general information on components and procedures that may be useful when installing or servicing a 502HO engine. Please read this entire publication before starting work. Also, please verify that all of the components listed in the Package Contents section below were shipped in the kit.

The information below is divided into the following sections: package contents, engine fastener torque specifications, component information, start- up and break- in procedures, 502HO engine specifications, additional parts that you may need to purchase, and a service parts list.

The 502HO engine is a fully assembled long block that also includes the intake manifold and water pump. This engine is assembled using brand new, premium quality components. The 502HO engine is manufactured on current production tooling; consequently you may encounter dissimilarities between the 502HO engine assembly and previous versions of the big block V8. In general, items such as motor mounts, accessory drives, exhaust manifolds, etc. can be transferred to a 502HO engine when installed in a vehicle originally equipped with a big block V8 engine. However, as noted in the following sections, there may be significant differences in the water pump, torsional damper, etc., between a 502HO engine and an older big block V8 engine. These differences may require modifications or additional components not included with the 502HO engine. When installing the 502HO engine in a vehicle not originally equipped with a big block V8, it may be necessary to adapt or fabricate various components for the cooling, fuel, electrical, and exhaust systems. Due to the wide variety of vehicles in which a 502HO engine can be installed, some procedures and recommendations may not apply to specific applications.

It is not the intent of these specifications to replace the comprehensive and detailed service practices explained in the GM service manuals.

For information about warranty coverage, please contact your local GM Performance Parts dealer.

Observe all safety precautions and warnings in the service manuals when installing a 502HO engine in any vehicle. Wear eye protection and appropriate protective clothing. Support the vehicle securely with jackstands when working under or around it. Use only the proper tools. Exercise extreme caution when working with flammable, corrosive, and hazardous liquids and materials. Some procedures require special equipment and skills. If you do not have the appropriate training, expertise, and tools to perform any part of this conversion safely, this work should be done by a professional.

TITLE 502HO Engine Long Block Specifications REV 15JA08	PART NO. 19172222	PAGE 1 OF 21
--	--------------------------	---------------------

ALL INFORMATION WITHIN ABOVE BORDER TO BE PRINTED EXACTLY AS SHOWN ON 8 1/2 x 11 WHITE 16 POUND BOND PAPER. PRINT ON BOTH SIDES, EXCLUDING TEMPLATES. TO BE UNITIZED IN ACCORDANCE WITH GMSPO SPECIFICATIONS.	DATE	REVISION	AUTH
	18AP07	Initial Release - Rusty Sampsel	
	15JA08	Revised - Rusty Sampsel	

The information contained in this publication is presented without any warranty. All the risk for its use is entirely assumed by the user. Specific component design, mechanical procedures, and the qualifications of individual readers are beyond the control of the publisher, and therefore the publisher disclaims all liability incurred in connection with the use of the information provided in this publication.

Legal and Emissions Information

This publication is intended to provide information about the 502HO engine and related components. This manual also describes procedures and modifications that may be useful during the installation of a 502HO engine. It is not intended to replace the comprehensive service manuals and parts catalogs which cover General Motors engines and components. Rather, it is designed to provide supplemental information in areas of interest to do-it-yourself-enthusiasts and mechanics.

This publication pertains to engines and vehicles which are used off the public highways except where specifically noted otherwise. Federal law restricts the removal of any part of a federally required emission control system on motor vehicles. Further, many states have enacted laws which prohibit tampering with or modifying any required emission or noise control system. Vehicles which are not operated on public highways are generally exempt from most regulations, as are some special interest and pre-emission vehicles. The reader is strongly urged to check all applicable local and state laws.

Many of the parts described or listed in this manual are merchandised for off-highway application only, and are tagged with the %Special Parts Notice+reproduced here:

Special Parts Notice

This part has been specifically designed for Off-Highway application only. Since the installation of this part may either impair your vehicle's emission control performance or be uncertified under current Motor Vehicle Safety Standards, it should not be installed in a vehicle used on any street or highway. Additionally, any such application could adversely affect the warranty coverage of such an on-street or highway vehicle

Chevrolet, Chevy, the Chevrolet Bow Tie Emblem, General Motors, and GM are all registered trademarks of the General Motors Corporation.

Package contents:

<u>Item</u>	<u>Description</u>	<u>Quantity</u>	<u>Part Number</u>
1	Base Engine Assembly	1	12568778
2	Short Block Instructions	1	19171883
3	Long Block Instructions	1	19172222

502HO Engine Torque Specifications:

Cylinder head bolt /screw	Long / Short Bolts
First pass	25/20 ft.-lbs. / 34/27 N·m
Second pass	50/40 ft.-lbs. / 68/54 N·m
Final pass	75/65 ft.-lbs. / 102/88 N·m
Distributor bolt/screw	18 ft.-lbs. / 25 N·m
Engine block oil gallery plug	15 ft.-lbs. / 20 N·m
Engine front cover bolt screw	106 in.-lbs. / 12 N·m
Flywheel bolt/screw	65 ft.-lbs. / 90 N·m
Intake manifold bolt/screw	
First pass	10 ft.-lbs. / 14 N·m
Second pass	25 ft.-lbs. / 34 N·m
Oil filter adapter bolt/screw	18 ft.-lbs. / 25 N·m
Oil level indicator tube bolt/screw	106 in.-lbs. / 12 N·m
Oil pan assembly bolt/screw	18 ft.-lbs. / 25 N·m
Oil baffle nut	30 ft.-lbs. / 40 N·m
Oil pan drain plug	15 ft.-lbs. / 20 N·m
Oil pump bolt/screw to rear crankshaft bearing cap	66 ft.-lbs. / 90 N·m
Oil pump cover bolt/screw	106 in.-lbs. / 12 N·m
Spark plug	22 ft.-lbs. / 30 N·m
Starter motor bolt/screw	35 ft.-lbs. / 48 N·m
Valve lifter guide retainer bolt/screw	18 ft.-lbs. / 25 N·m
Water pump bolt/screw	30 ft.-lbs. / 40 N·m
Rocker arm bolt	45 ft.-lbs. / 61 N·m

Note: These torque values are in addition to those documented within the short block instructions.

Component Information:

Cylinder heads:

The 502HO engine comes with fully assembled cylinder heads, GM Part Number 12562920. These cylinder heads are cast iron, rectangle port heads with 118cc combustion chambers, 2.19" intake valves, and 1.88" exhaust valves.

Cylinder Head Installation:

Installation is the same as for original equipment cylinder heads. Be sure to thoroughly clean the surface of the block and the surface of the cylinder head prior to installing. Apply liquid Teflon to all head bolts that protrude into coolant passages. Tighten the bolts alternately per the sequence and pattern shown below. Apply torque in 25 ft.lb. increments over two repetitions with the third repetition to the final tightening specification. A re-torque of the cylinder head bolts is recommended after heat cycling the engine.

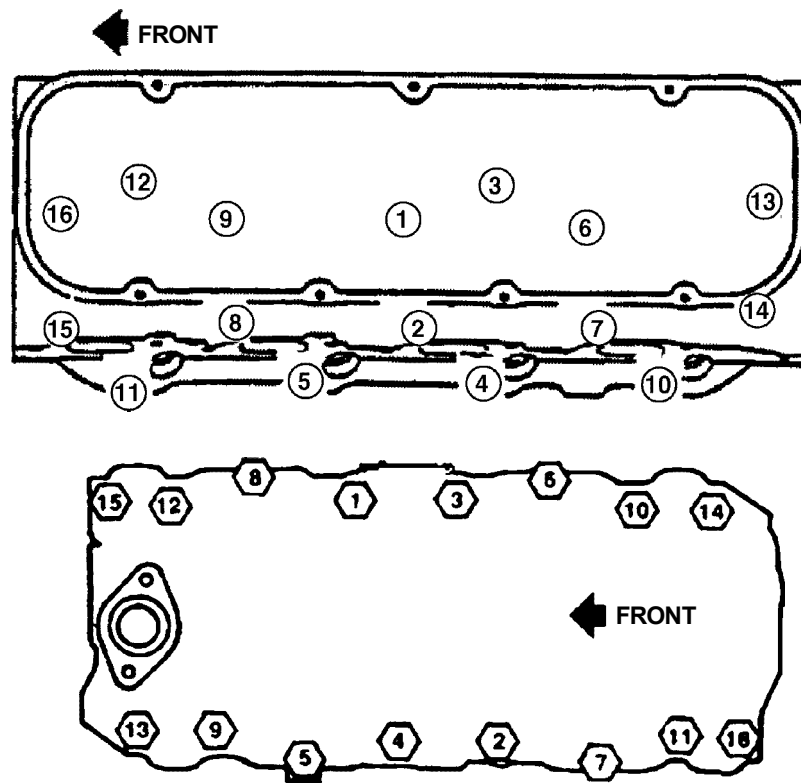

Caution

This engine assembly needs to be filled with oil and primed. You should add the specified oil (see start-up instructions) to your new engine. Check the engine oil level on the dipstick and add accordingly.

Start-up and Break-in Procedures

1. After installing the engine, ensure the crankcase has been filled with 5W30 motor oil (non-synthetic to the recommended oil fill level on the dipstick. Also check and fill as required any other necessary fluids such as coolant, power steering fluid, etc.
2. The engine should be primed with oil prior to starting. Follow the instructions enclosed with the tool. To prime the engine, first remove the distributor to allow access to the oil pump drive shaft. Note the position of the distributor before removal. Install the oil priming tool, GM part number 12368084. Using a 1/2" drill motor, rotate the engine oil priming tool clockwise for three minutes. While you are priming the engine, have someone else rotate the crankshaft clockwise to supply oil throughout the engine and to all the bearing surfaces before the engine is initially started. This is the sure way to get oil to the bearings before you start the engine for the first time. Also, prime the engine if it sits for extended periods of time. Reinstall the distributor in the same orientation as it was removed.
3. Safety first. If the vehicle is on the ground, be sure the emergency brake is set, the wheels are chocked and the car cannot fall into gear. Verify everything is installed properly and nothing was missed.
4. Start the engine and adjust the initial timing. If using the HEI distributor P/N 93440806, set the ignition timing to 4° before top dead center (BTDC) at 650 rpm with the vacuum advance line to the distributor disconnected and plugged. This setting will produce 26° of total advance at wide-open throttle (WOT) when using the HEI distributor P/N 93440806. The HEI vacuum advance canister should remain disconnected. This engine is designed to operate using only the internal centrifugal advance to achieve the correct timing curve. Rotate the distributor counterclockwise to advance the timing. Rotate the distributor clockwise to retard the timing.

5. When possible, you should always allow the engine to warm up prior to driving. It is a good practice to allow the oil sump and water temperature to reach 180°F before towing heavy loads or performing hard acceleration runs.
6. Once the engine is warm, Double check the total advance timing is 30° at 4000 RPM if using the deluxe engine configuration.
7. The engine should be driven at varying loads and conditions for the first 30 miles or one hour without wide open throttle (WOT) or sustained high RPM accelerations.
8. Run five or six medium throttle (50%) accelerations to about 4000 RPM and back to idle (0% throttle) in gear.
9. Run two or three hard throttle (WOT 100%) accelerations to about 4000 RPM and back to idle (0% throttle) in gear.
10. Change the oil and filter. Replace with 5W30 motor oil (not synthetic) and a PF1218 AC Delco oil filter. Inspect the oil and the oil filter for any foreign particles to ensure that the engine is functioning properly.
11. Drive the next 500 miles under normal conditions or 12 to 15 engine hours. Do not run the engine at its maximum rated engine speed. Also, do not expose the engine to extended periods of high load.
12. Change the oil and filter. Again, inspect the oil and oil filter for any foreign particles to ensure that the engine is functioning properly.
13. Do not use synthetic oil for break-in. It would be suitable to use synthetic motor oil after the second recommended oil change and mileage accumulation. In colder regions, a lower viscosity oil may be required for better flow characteristics.

502HO Engine Specifications:

Compression 8.75:1
 Cylinder Head: Cast iron, rectangular port
 Valve Diameter (Intake/Exhaust): 2.19"/1.88"
 Chamber Volume: 118cc
 Camshaft: Hydraulic roller tappet
 Lift:510" intake, .540" exhaust
 Duration: 211(intake, 230(exhaust @ .050" tappet lift
 Centerline: 112(ATDC intake, 112(BTDC exhaust
 Rocker Arm Ratio: 1.7:1, stamped steel
 Oil Pressure (Minimum): 6 psig @ 1000 RPM
 18 psig @ 2000 RPM
 24 psig @ 4000 RPM
 Recommended Oil: 5W30 synthetic motor oil (after break-in)
 Oil Filter: AC Delco part # - PF 1218
 Valve Lash Torque bolt to 45 ft. lbs.
 Fuel: Premium unleaded - 92 (R+M/2)
 Maximum Engine Speed: 5500 RPM
 Spark Plugs: AC Delco MR43T
 Spark Plug Gap040+
 Firing Order: 1-8-4-3-6-5-7-2

Information may vary with application. All specifications listed are based on the latest production information available at the time of printing.

Additional parts that may be needed:

Flywheel / Flexplate:

Like all big block V8 engines, the 502HO engine has 3.58" diameter flywheel flange bolt pattern. This engine comes equipped with a 14" diameter flexplate with a 168 tooth ring gear, GM Part Number 10185034. If your application requires a flywheel, GM Part Number 14096987, should be used. This flywheel is 14" diameter, 168 tooth ring gear, and is a for 11" diameter clutch. Use flywheel bolt GM Part Number 12337973 (6 required).

Pilot Bearing:

You must install a pilot bearing in the rear of the crankshaft if the engine will be used with a manual transmission. The pilot bearing aligns the transmission input shaft with the crankshaft centerline. A worn or misaligned pilot bearing can cause shifting problems and rapid clutch wear. A roller pilot bearing, GM Part Number 14061685, is recommended for this engine. This heavy-duty bearing adds an extra margin of reliability to a high performance drivetrain.

Oil Pan:

The 502HO engine includes oil pan, GM Part Number 10240721. This six-quart pan was originally designed for marine and truck usage and may cause interference problems when installed in certain applications. Check for clearance before installation of the engine. If the six-quart pan will not fit into your application, GM Part Number 12495360 is recommended as a substitute. This is a four-quart, right-hand dipstick oil pan, which comes with the gasket, four main cap bolts, oil pump screen, dipstick and tube.

Headers:

A 502HO engine should be equipped with a header exhaust system for maximum performance in applications where a non-production exhaust system is legal. For street performance and limited competition applications, the recommended header configuration is 2" diameter primary pipes, 36 inches long, with 3 1/2" diameter collectors. Use 3" diameter tailpipes with a balance tube (1/2" pipe) and low restriction mufflers.

Rocker Covers:

The 502HO engine comes equipped with die cast rocker covers, GM Part Numbers 12553666 and 12553667. Additional tall and short valve covers are available. Please see the website at www.GMPerformanceparts.com or your local GM Performance Parts dealer. When using either the cast aluminum or the tall, chrome rocker covers; ensure that enough clearance exists between the cover and the brake booster.

502HO Service Parts List:

<u>Part #</u>	<u>Quantity</u>	<u>Name</u>	<u>Part #</u>	<u>Quantity</u>	<u>Name</u>
10237292	1	Block Asm, Eng	3942410	2	Nut, Conn Rod
6264902	1	Seal, Rr Brg Cap (O Ring)	12533507	1	Piston Kit (W/Pin & Rings) (Std)
10181306	1	Bearing, Cr/Shf Up	12524293	1	Ring Kit, Pstn (Std)
12529885	3	Bearing, Cr/Shf Up	10181277	16	Bearing, Conn Rod
12529885	3	Bearing, Cr/Shf Lwr	10240721	1	Pan Asm, Oil
10181306	1	Bearing, Cr/Shf Lwr	3536964	1	Plug Asm, Oil Pan Drn
10181307	1	Bearing, Cr/Shf Thr Up	3536966	1	Seal, Oil Pan Drn Plug
10181307	1	Bearing, Cr/Shf Thr Lwr	10106407	1	Gasket, Oil Pan
12562920	2	Head Asm, Cyl (W/ Vlv)	12555167	1	Pump Asm, Oil (W/ Scrn)
12562925	1	Head Asm, Cyl	10230954	1	Cover Asm, Eng Frt (W/ Tmg Ind)
14097049	4	Valve, Exh (Std)	10191640	1	Seal Asm, Cr/Shf Frt Oil
14097002	8	Spring Asm, Vlv	10198910	1	Gasket, Eng Frt Cvr
12550421	8	Cap, Vlv Spr	12562234	1	Pump Asm, Wat
12550422	8	Seal, Vlv Stem Oil	3860039	2	Gasket, W/Pmp
3947880	16	Key, Vlv Stem	19131359	1	Manifold, Int
3875916	8	Shim, Vlv Spr	14097043	2	Gasket, Int Manif Si
14097045	4	Valve, Int (Std)	24502611	1	Camshaft Asm
14097046	1	Valve, Int .003" O.S	12560176	1	Sprocket, Cm/Shf
14097047	1	Valve, Int .015" O.S	9424877	3	Bolt/Screw, Cm/Shf Spkt
14097048	1	Valve, Int .030" O.S	12560177	1	Sprocket, Cr/Shf
14097001	2	Gasket, Cyl Hd	10114177	1	Chain Asm, Tmg
10141204	24	Bolt/Screw, Cyl Hd	10227762	8	Rod Asm, Vlv Push
10141205	8	Bolt/Screw, Cyl Hd	10227763	8	Rod, Exh Vlv Push
10183723	1	Crankshaft Asm	17120061	16	Lifter Asm, Vlv
10101164	1	Seal Asm, Cr/Shf Rr Oil	12551397	8	Guide, Vlv Lftr
14097040	1	Deflector, Cr/Shf Oil	12562369	8	Guide, Vlv Lftr Push Rod
10216339	1	Balancer Asm, Cr/Shf	12553666	1	Cover Asm, Vlv Rkr Arm
10114166	1	Key, Torsional Dpnr	10126727	1	Gasket, Vlv Rkr Arm Cvr
10126796	1	Bolt/Screw, Cr/Shf Balr	12553667	1	Cover Asm, Vlv Rkr Arm
3864814	1	Washer, Cr/Shf Balr	14097072	16	Arm, Vlv Rkr
10185034	1	Flywheel Asm, Eng	10213466	16	Ball, Vlv Rkr Arm
3727207	6	Bolt/Screw, Flywhl	10114123	16	Bolt/Screw, Vlv Rkr Arm
10198922	8	Rod, Conn	10198929	1	Stud, Vlv Rkr Arm Piv
3963571	1	Cap, Conn Rod	10198930	1	Nut, Vlv Rkr Arm
14096148	2	Bolt/Screw, Conn Rod	25109403	8	Spark Plug Asm

ALL INFORMATION WITHIN ABOVE BORDER TO BE PRINTED EXACTLY AS SHOWN ON 8 1/2 x 11 WHITE 16 POUND BOND PAPER. PRINT ON BOTH SIDES, EXCLUDING TEMPLATES. TO BE UNITIZED IN ACCORDANCE WITH GMSPO SPECIFICATIONS.	DATE	REVISION	AUTH