

Accessory Wiring Harness Package Installation

Instruction ID: 86816617

Table 1: [Kit Contents](#)

Table 2: [Power Distribution Box In-line 8-Way Connector](#)

Installation Instructions Part Number

86816617

Kit Contents

| Qty | Description |
|-----|---------------------------|
| 1 | Lamp Bracket |
| 1 | Wire Harness |
| 10 | Tie Strap |
| 1 | Wire Harness |
| 1 | Wire Harness Grommet |
| 1 | Relay |
| 2 | Splice Sleeves |
| 1 | Fuse - 15A |
| 1 | Harness Connector |
| 1 | Harness Connector |
| 1 | Installation Instructions |

Preliminary Procedures

Warning: Always ensure the Battery Maintenance Mode is inactive before disconnecting the low voltage 12 volt battery (or batteries). This mode can be active with the ignition off, regardless of whether the vehicle charging cord is plugged in or not. When this mode is active, the on-board high voltage battery charger(s) will energize the 12 volt battery cables and charge the 12 volt battery (or batteries). Disconnecting any battery cables while this mode is active may result in an electrical shock or a burn from hot battery cable leads.

1. Check the 12 volt battery voltage with a digital multimeter before disconnecting any battery cables leads. If the voltage is 13.5 volts or above, the Battery Maintenance Mode is active. The technician must wait for the T18 battery charger to deactivate before disconnecting the battery negative cable. [Charging System Description and Operation](#)
2. Disconnect the 12 volt negative battery cable. Refer to [Battery Negative Cable Disconnection and Connection](#) in Vehicle Service Manual.

Note: This accessory requires the battery distribution engine compartment fuse block and must be purchased separately.

3. Install the battery distribution engine compartment fuse block. Refer to [Battery Distribution Engine Compartment Fuse Block Package Installation](#) in Vehicle Accessory Installation Manual.
4. Read all instructions before performing procedure.
5. Inspect KIT to verify all parts are included.

Procedure

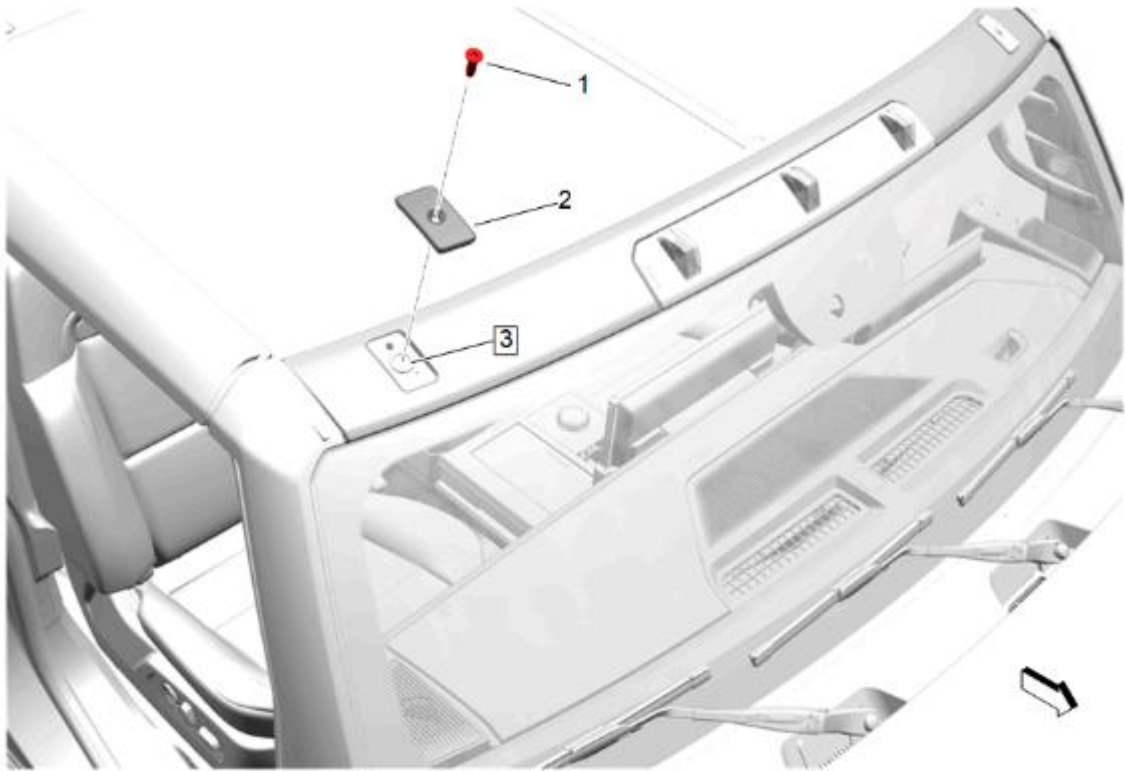

© 2024 General Motors. All rights reserved.

1. Remove the bolt (1) and right luggage cover cap (2) from passenger side of vehicle.
2. Remove the passenger side sunshade. Refer to [Sunshade Replacement](#) in Vehicle Service Manual.

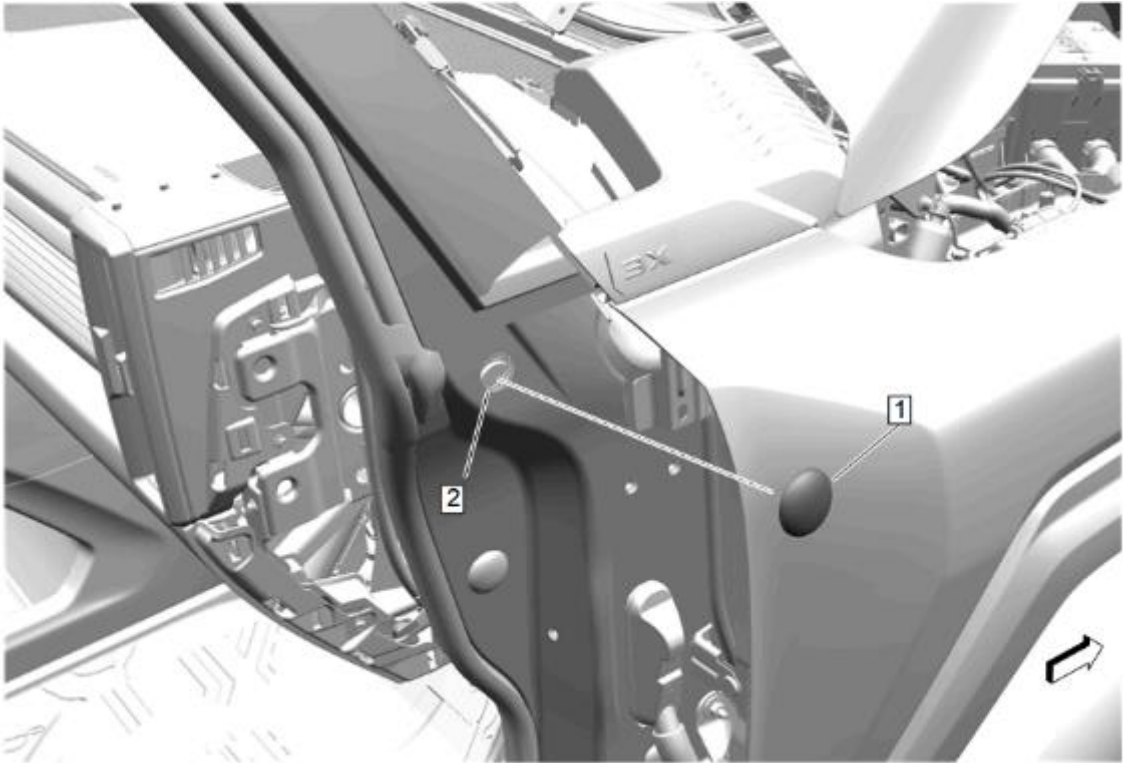

3. Remove the plug (1) from the passenger front pillar (2).

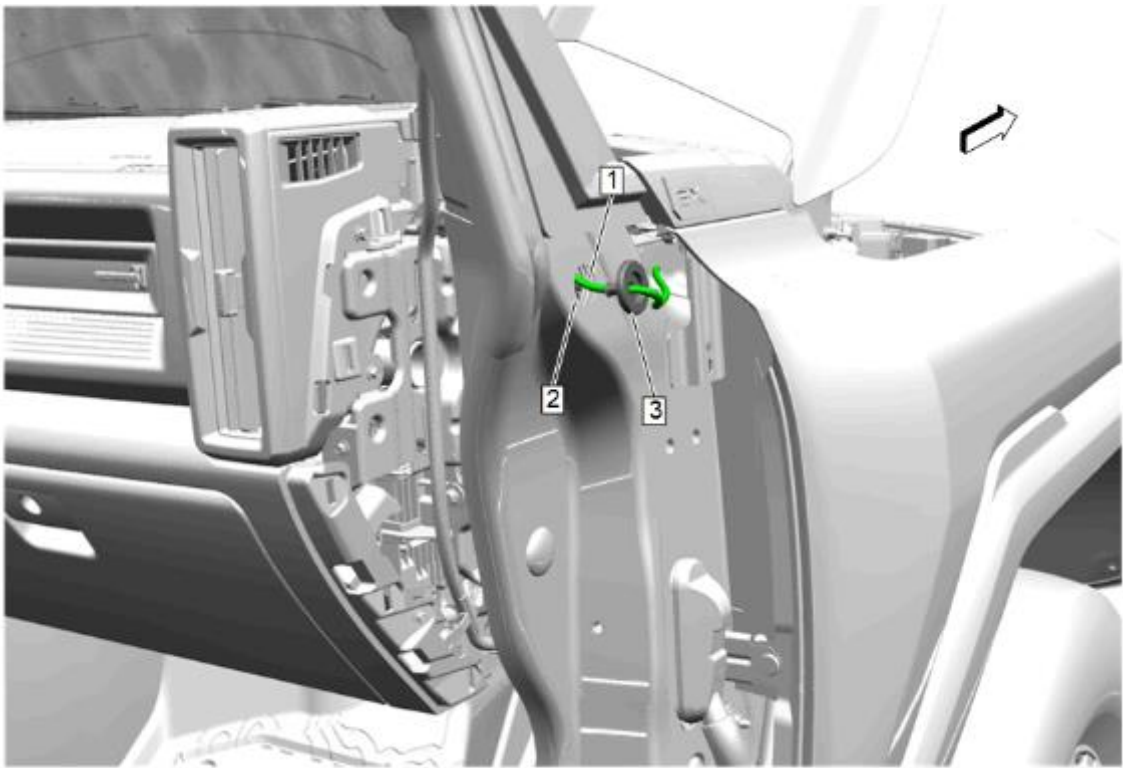

4. Route the harness (1) through the hole (2) in the passenger front pillar and seat the harness grommet (3) to hole (2).

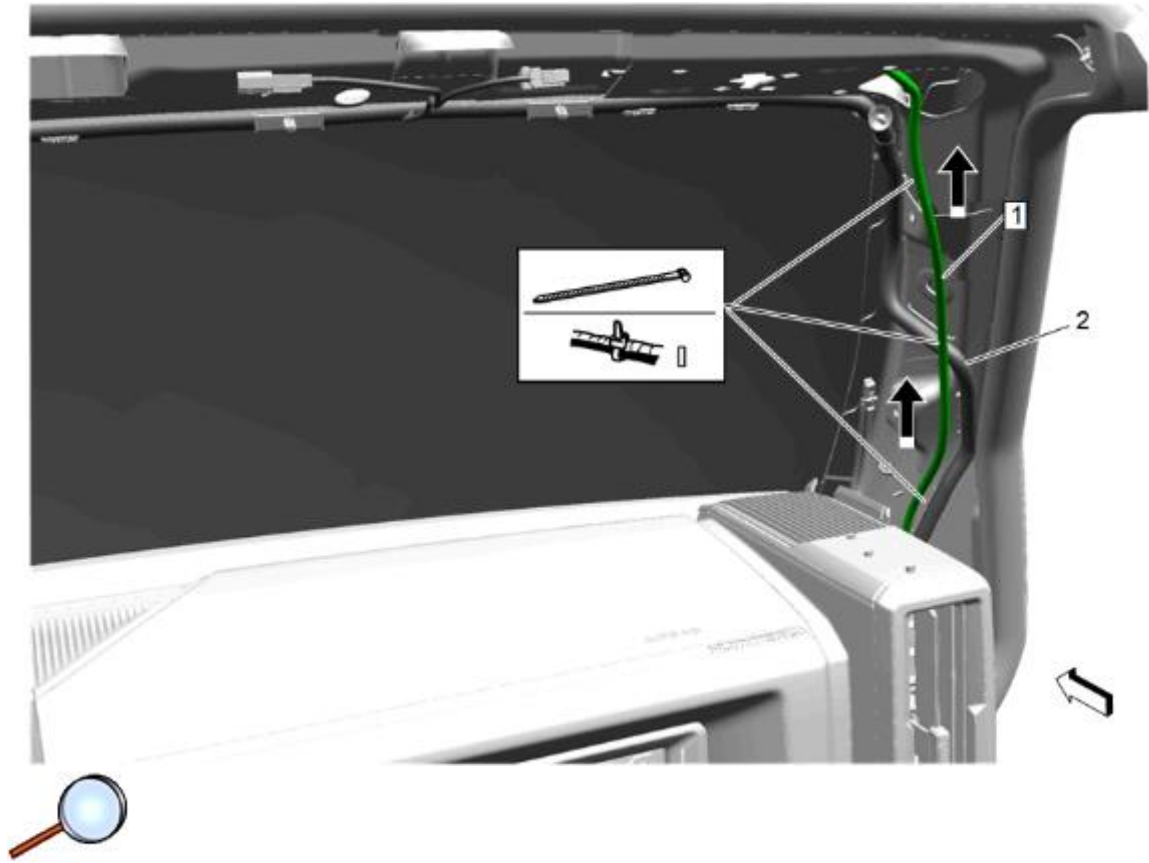

5. Continue to route harness (1) up the passenger A pillar and secure harness to existing harness (2) with tie straps. Trim excess off tie straps.

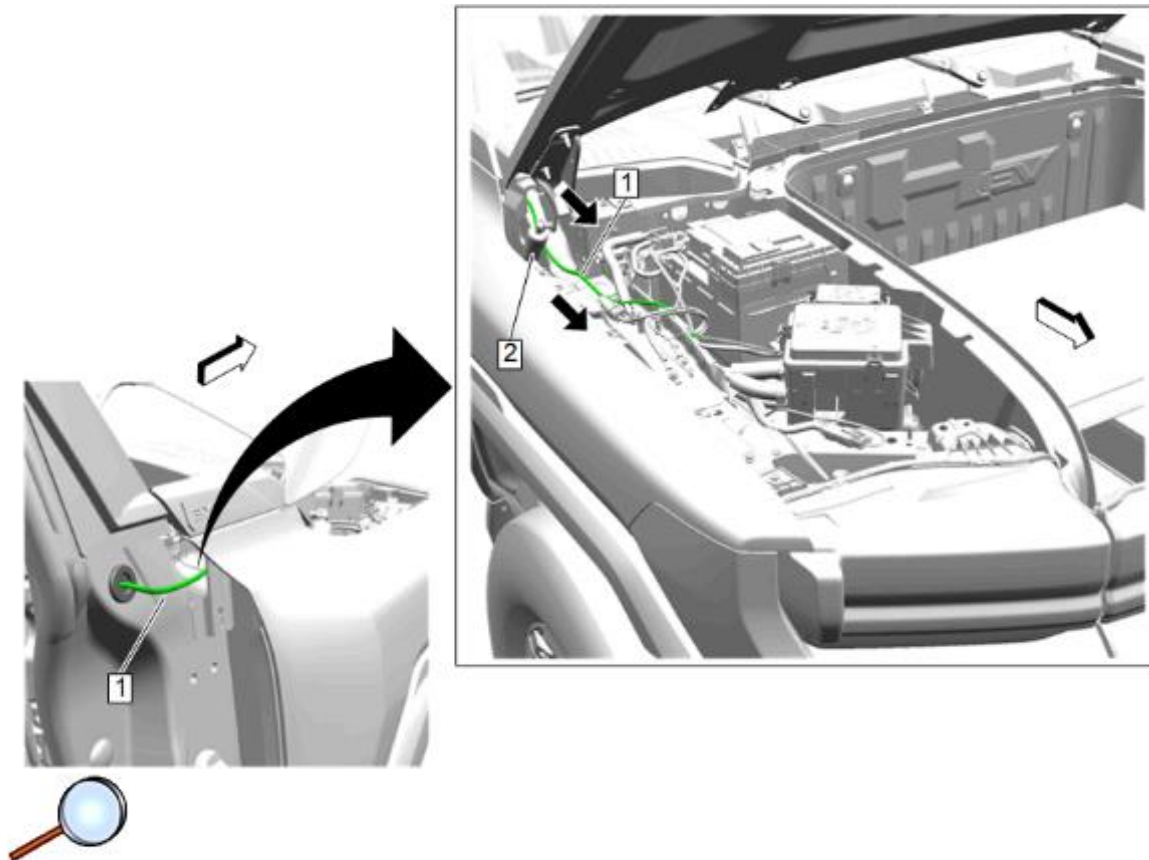

6. Route the other end of harness (1) along passenger side front fender area, inboard of the hood strut (2).

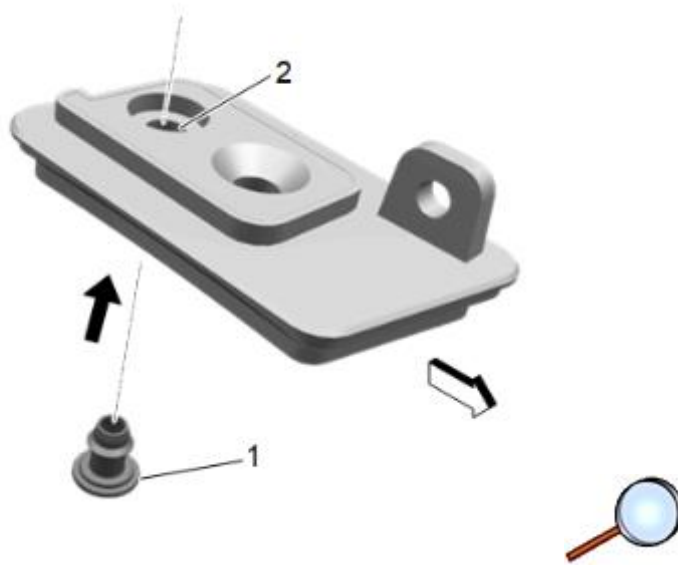

7. Install the grommet (1) to the bottom side of the base plate (2).

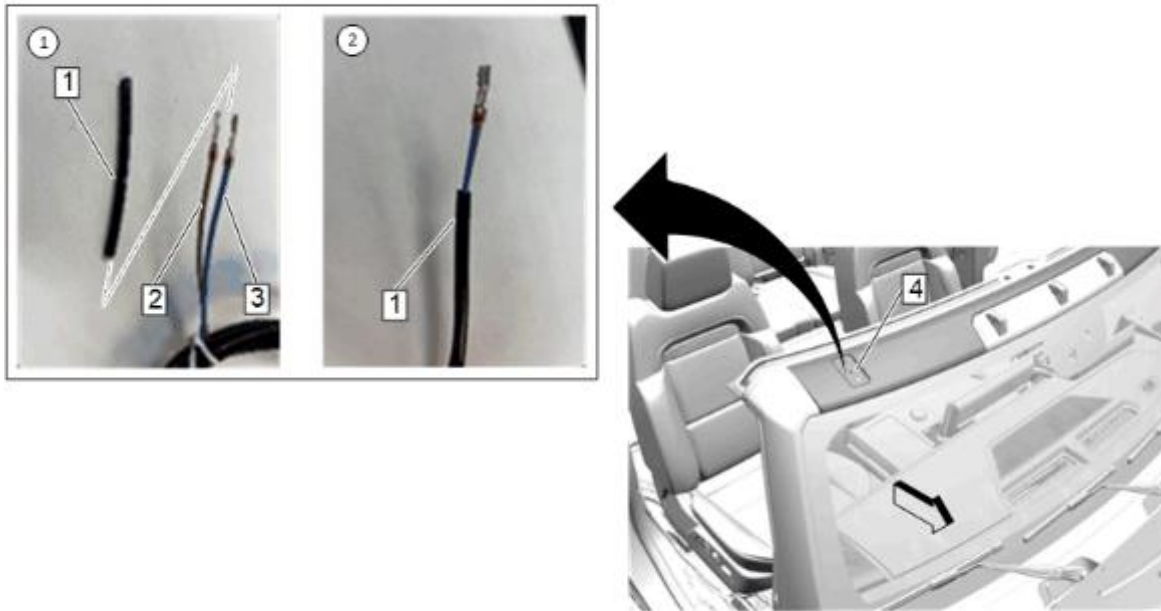

8. Pass the brown and blue wires of harness through the top hole of passenger roof (4) where luggage cover cap was removed.

9. Install the vinyl tubing (1) over brown (2) and blue (3) wires at the roof panel area (4).

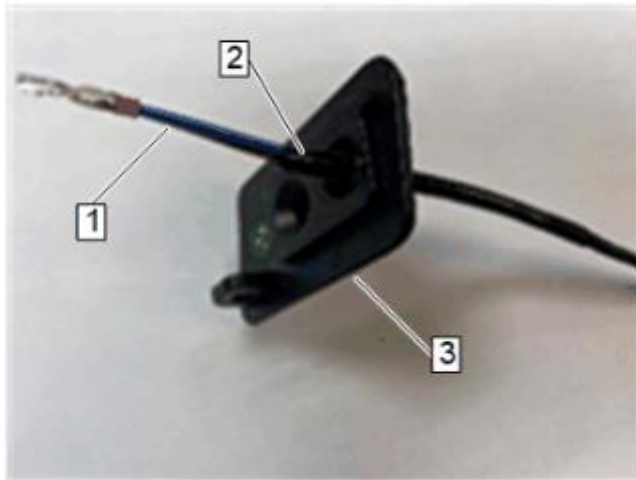

10. Insert the brown and blue wires (1) with the vinyl tubing through the grommet (2) on the base plate (3).

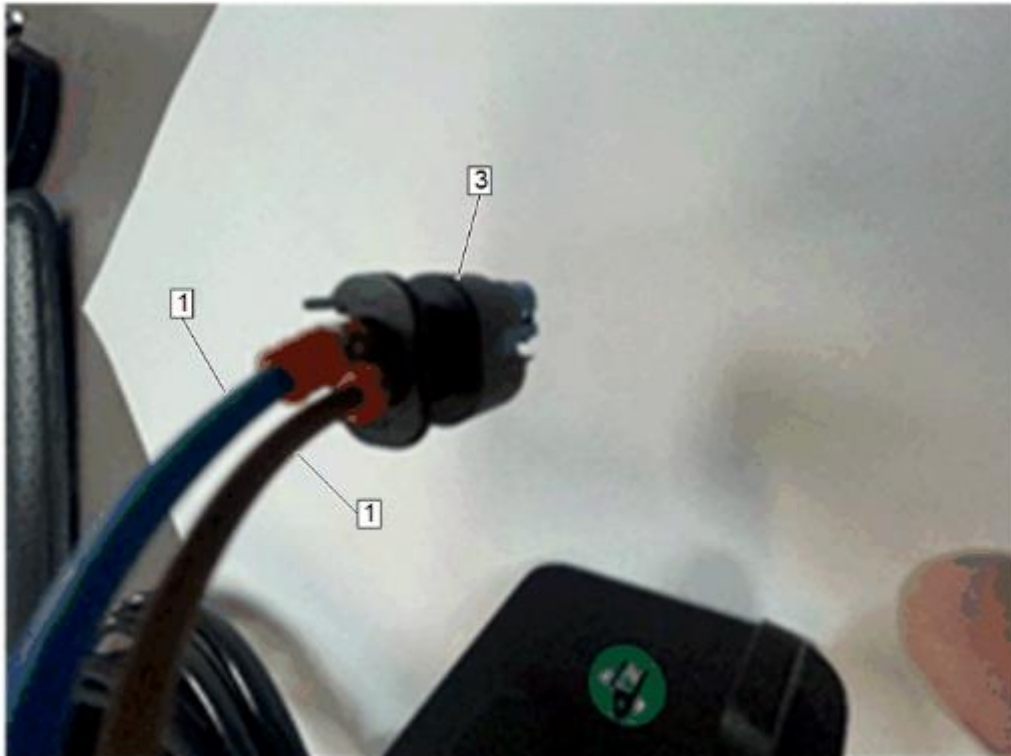

11. Insert the terminals of harness (1) into the 2-way connector (3) (Brown to cavity 2 and Blue to Cavity 1).

Note: Before step 11, You have to remove the blue clip on the connector. That is the locking mechanism that keeps the pins seated in, and will also keep them from inserting. Once you remove the blue clip, insert the terminals by rotating them until they slide in per step 11. Then once they are inserted put the blue lock clip back on.

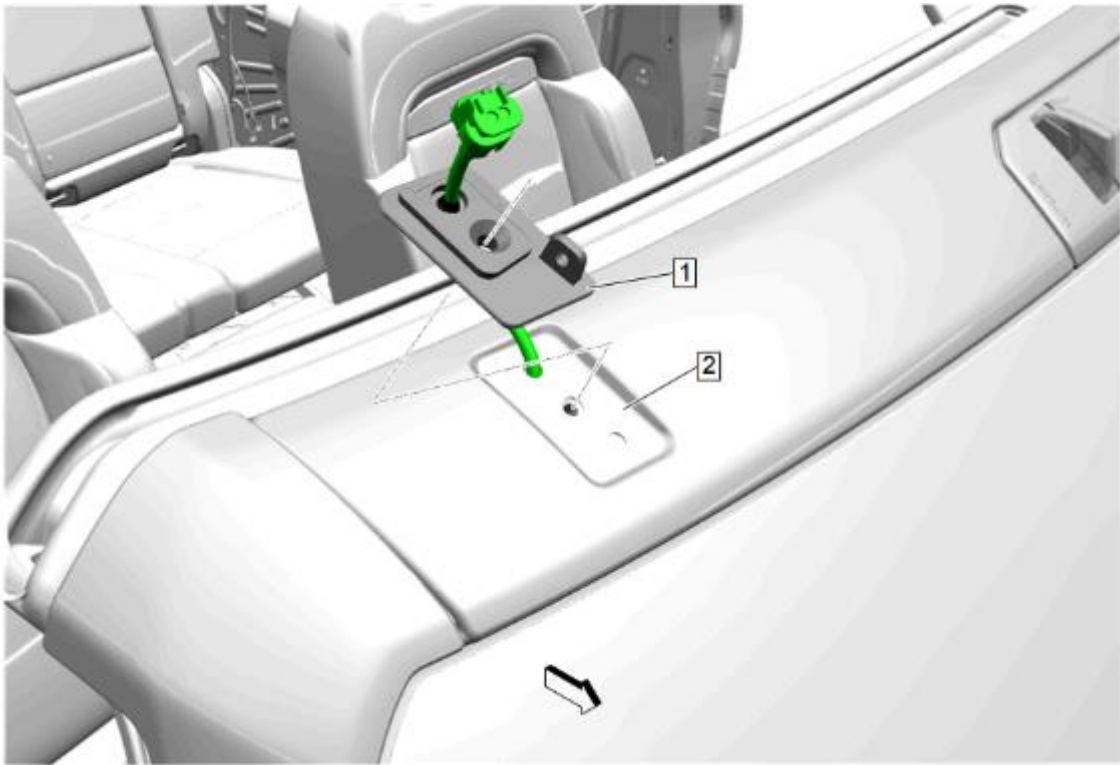

12. Push excess wiring back into hole and install the base plate (1) to the roof panel (2).

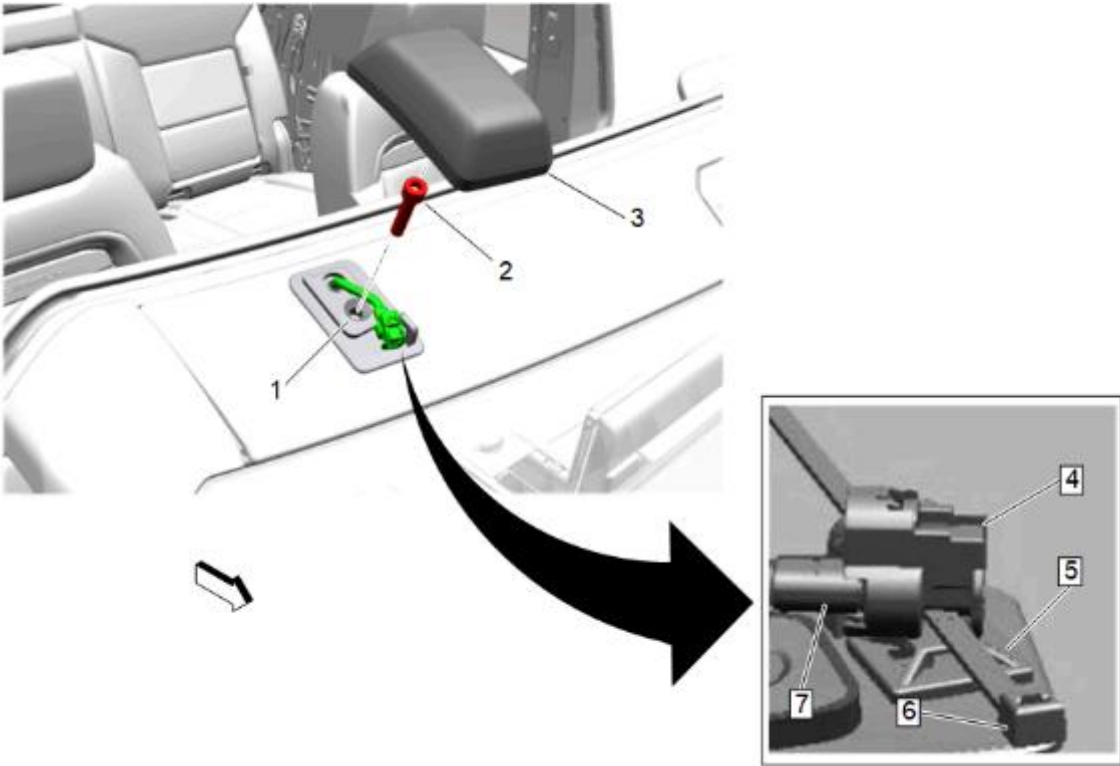

Caution: Use the correct fastener in the correct location. Replacement fasteners must be the correct part number for that application. Fasteners requiring replacement or

fasteners requiring the use of thread locking compound or sealant are identified in the service procedure. Do not use paints, lubricants, or corrosion inhibitors on fasteners or fastener joint surfaces unless specified. These coatings affect fastener torque and joint clamping force and may damage the fastener. Use the correct tightening sequence and specifications when installing fasteners in order to avoid damage to parts and systems.

13. Install fastener (2) to base plate (1) and tighten to 22 +/- 3 N.m (16 lb ft).
14. Install temporary cap (4) to harness connector (7).
15. Install tie strap mount (5) to base plate and secure temporary cap (4) to tie strap mount with tie strap (6). Trim excess off tie strap.
16. Install cap (3) to base plate (1).

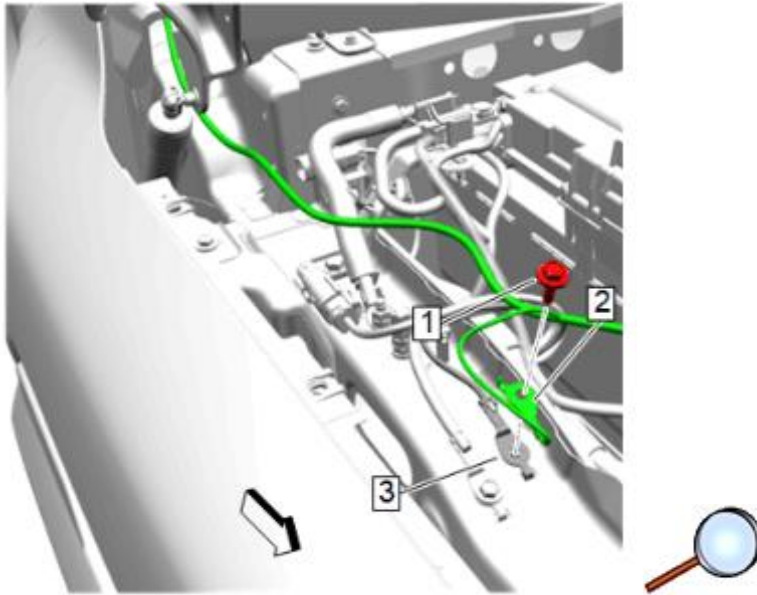

17. Remove the existing vehicle wiring ground bolt (1) near the electrical center and stack the accessory harness ring terminal (2) over the vehicle ground terminal (3).
18. Reinstall ground bolt (1) and tighten to 9 N.m (80 lb in).

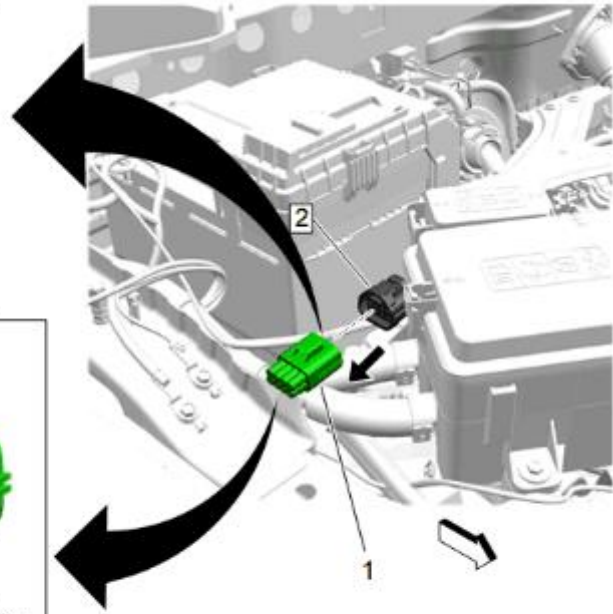
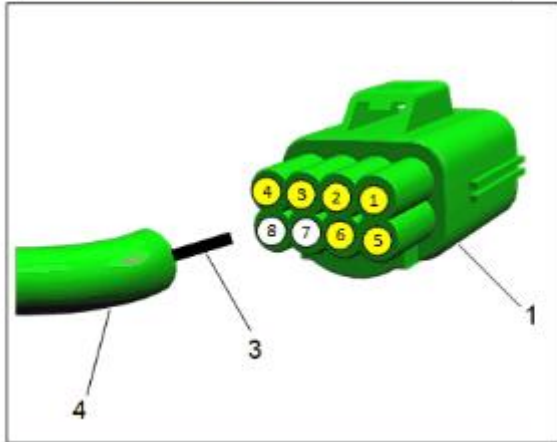

Note: Refer to the Power Distribution Box In-line 8-Way Connector table at the end of these instructions.

Note: Remove the cavity plug from the first non-used available location starting with #1 toward #6 (Do Not Use #7 or #8).

19. Remove the 8-way connector (1) from the power distribution box in-line connector (2).
20. Inside the 8-way connector (1), unseat the TPA (5) with a suitable hook tool.
21. Remove the cavity plug from the selected cavity and install terminal (3) of main harness (4) into 8-way connector (1) until seated.
22. Snap the TPA (5) back into position inside 8-way connector (1) to secure terminal pin.

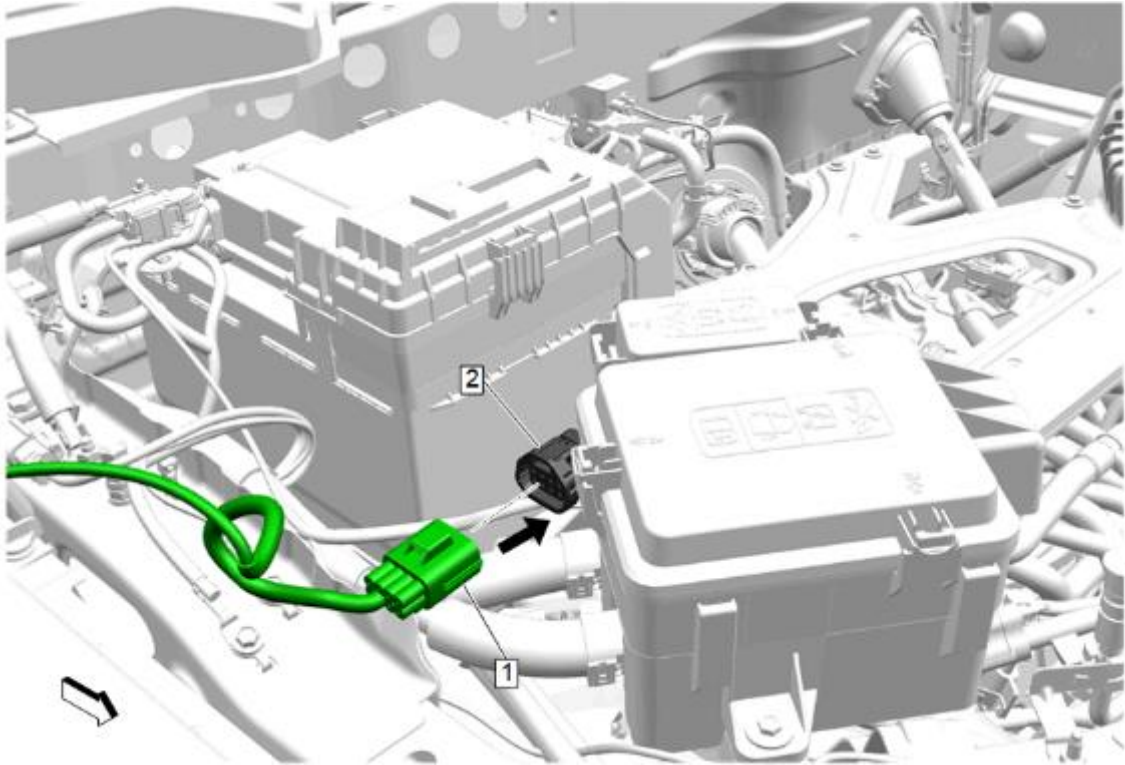

23. Connect the 8-way connector (1) to the power distribution box in-line connector (2). Secure harness to existing harness with supplied tie straps making sure harness does not come into contact with any sharp edges. Trim excess off tie straps.

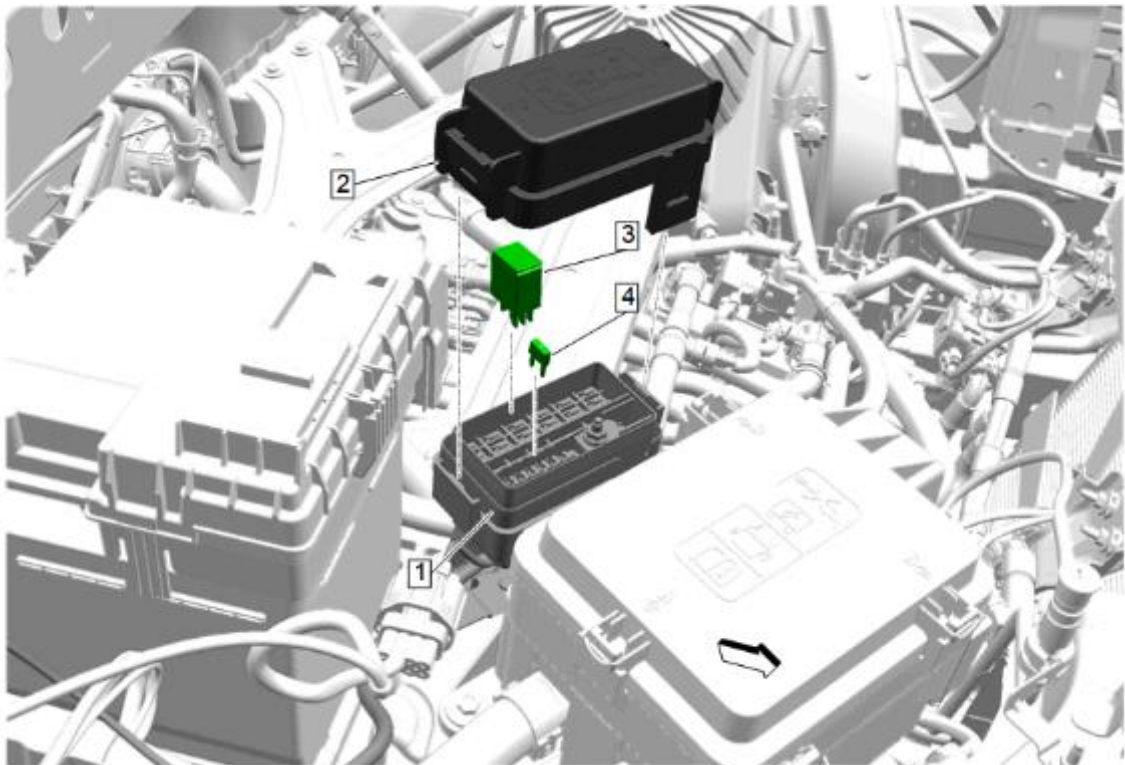

24. Remove cover (2) from the power distribution box (1).
25. Install relay (3) and fuse (4) to power distribution box cavity that corresponds to the previously selected cavity on the power distribution box in-line 8-way connector
26. Reinstall cover (2) to the power distribution box (1).
27. Connect the 12 volt negative battery cable. Refer to [Battery Negative Cable Disconnection and Connection](#) in Vehicle Service Manual.
28. Reinstall the passenger side sunshade and the previously removed interior trim components. Refer to [Sunshade Replacement](#) in Vehicle Service Manual.

Power Distribution Box In-line 8-Way Connector

| Connector Pin-Out | Wire Color | Relay Position | Fuse Position | Touch Screen Switch |
|--------------------------|-------------------|-----------------------|----------------------|----------------------------|
| 1 | Red/Yellow | Relay 1 | Fuse 1 | 1 |
| 2 | Red/Blue | Relay 2 | Fuse 2 | 2 |
| 3 | Red/Gray | Relay 3 | Fuse 3 | 3 |
| 4 | Red | Relay 4 | Fuse 4 | 4 |
| 5 | Red/White | Relay 5 | Fuse 5 | 5 |
| 6 | Red/Brown | Relay 6 | Fuse 6 | 6 |
| 7 | NC | NC | NC | NA |
| 8 | NC | NC | NC | NA |