

Pontiac Solstice, Saturn Sky, Windscreen Installation

Kit Contents

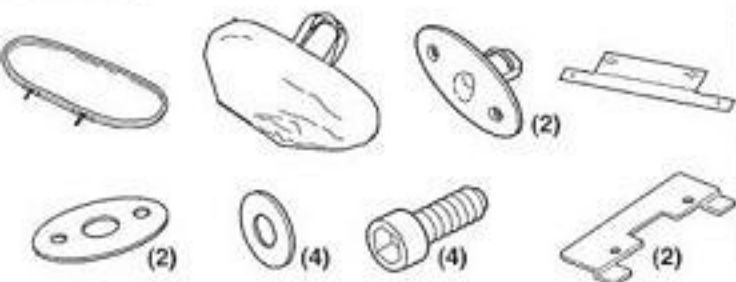

Tools Required

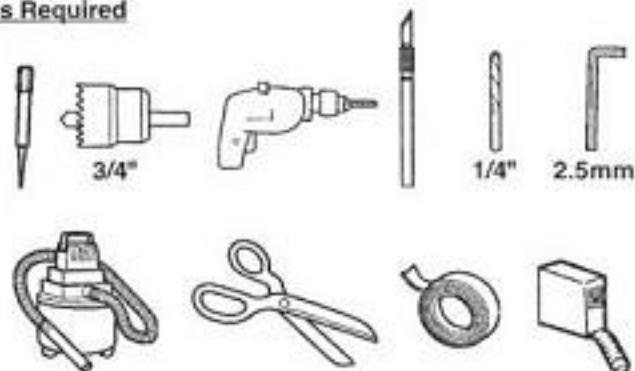

1. Lift/open decklid, refer to owner's manual for specific instructions.

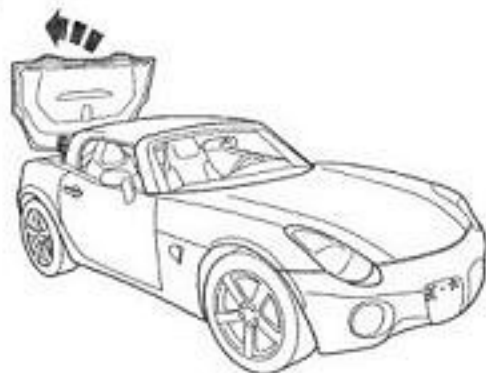

2. Lower convertible top fully, refer to owner's manual for specific instructions.



Wind Deflector Measuring Instructions:

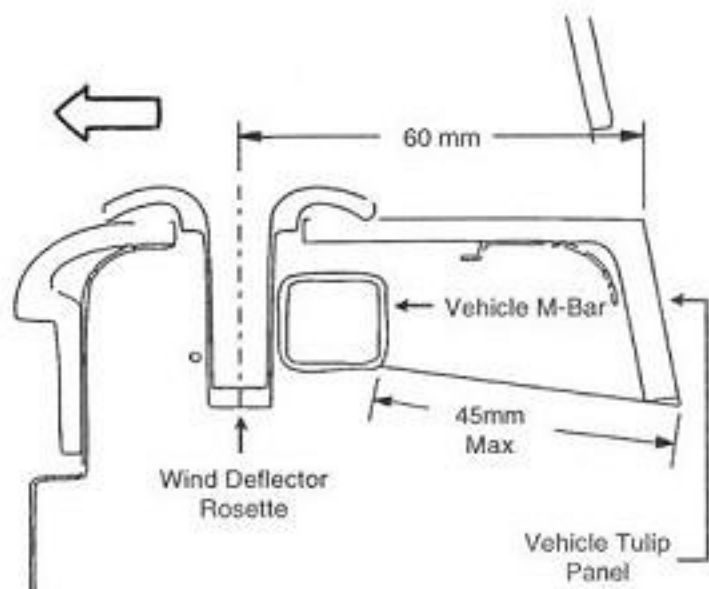

CAUTION: To ensure the Windscreen can be installed in your vehicle first measure the location of the M-Bar to determine if Windscreen Rosette can be installed into the Tulip Panel. If the M-Bar is more than 45mm forward from the back edge of the Tulip Panel as shown the Windscreen can not be installed. If measurement is 45mm or less continue to the next step.

3. Using scissors, cut out template and fold accordingly.

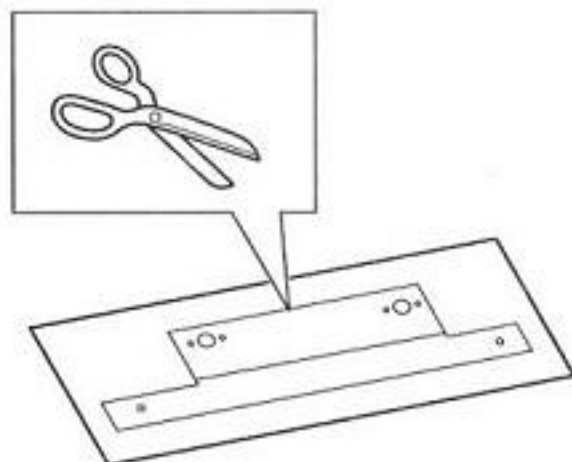

4. Place template on top of panel. Align template with two screws located on rear edge of panel.

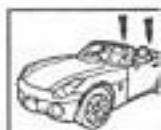
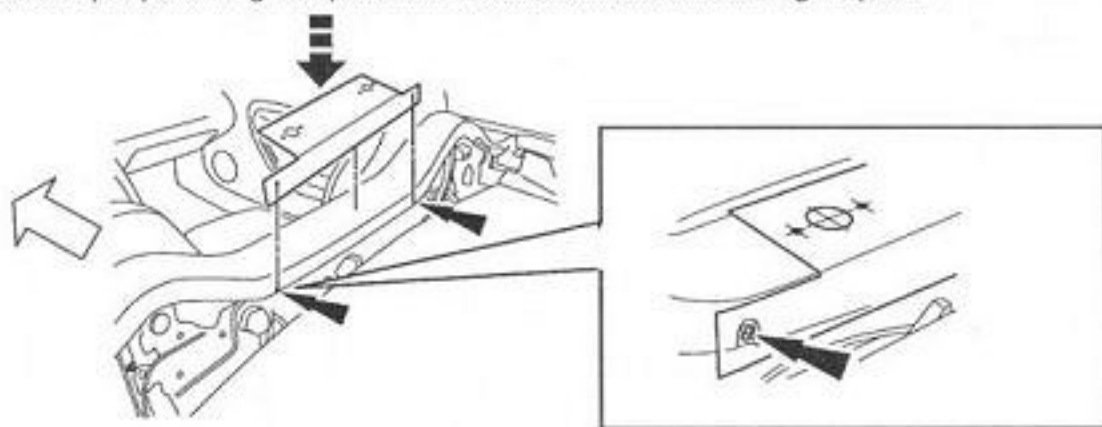

5. Once template is aligned and seated properly, tape template securely to panel

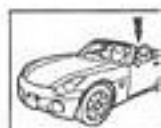
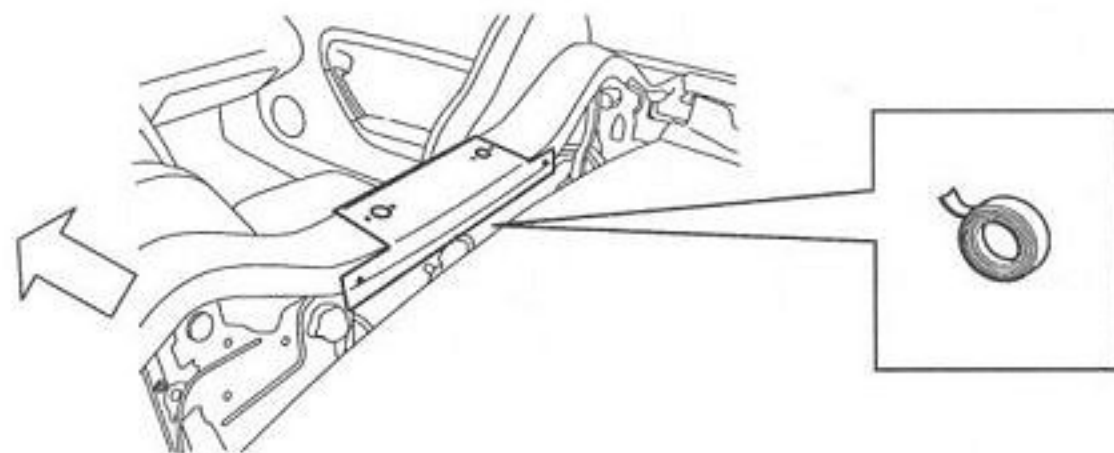

6. Using a scribe/center-punch, mark center of each hole on template.

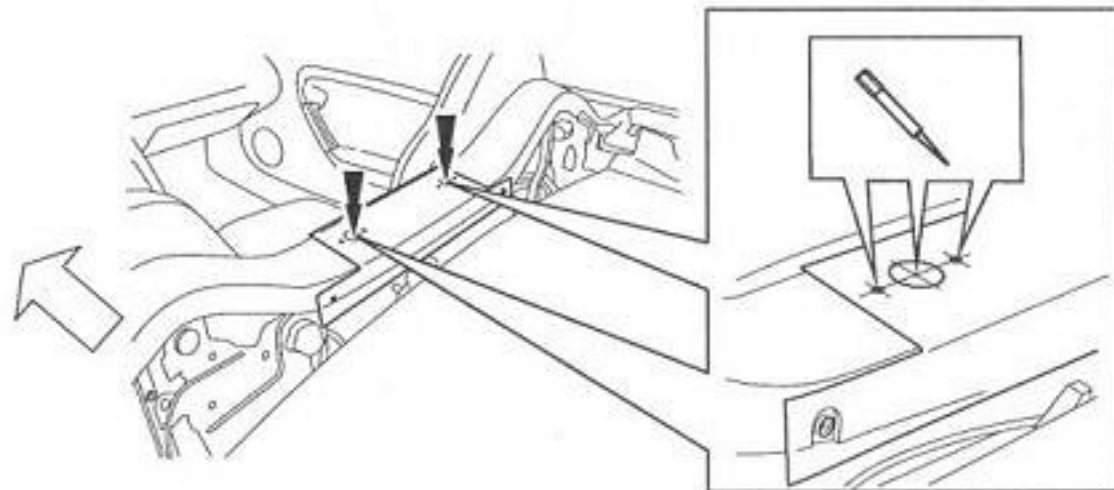

7. Remove template from panel.

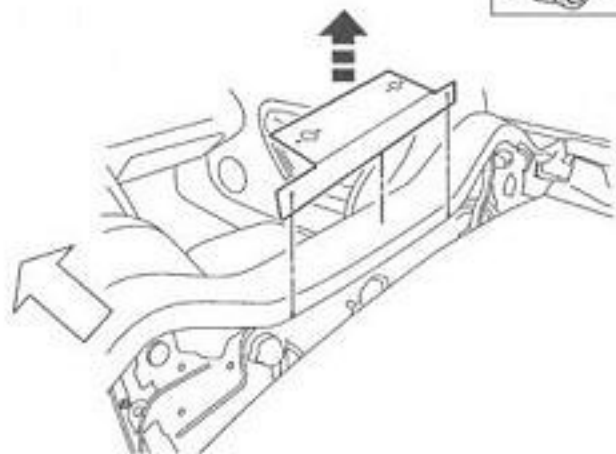
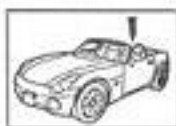

8. Using tape measure/scale, check that scribe/center-punch marks are 60mm from back edge of panel.

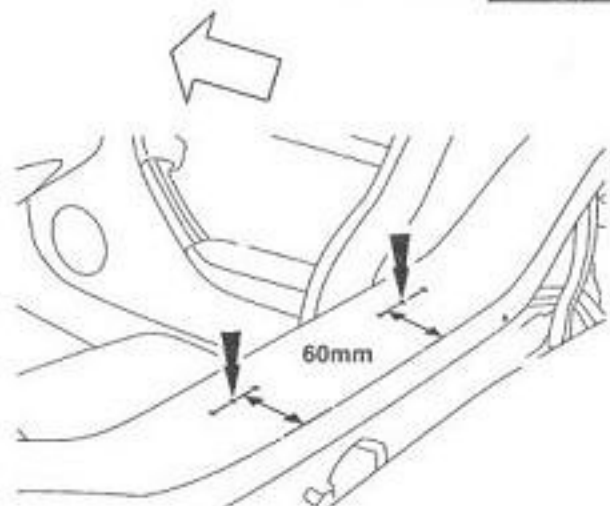

NOTE: Two person operation!

9. Using drill, 3/4" hole-saw and shop vac, align hole-saw tip to scribe/center-punch mark of center hole and begin drilling. While drilling, have another person using shop vac to remove debris. Make sure all debris is removed before you proceed any further.

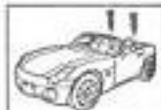
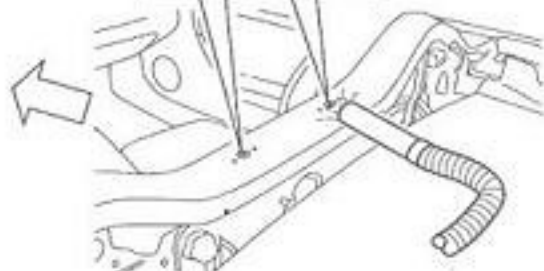
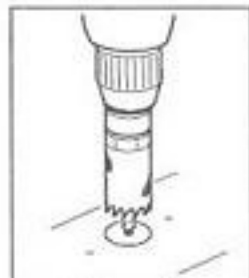

NOTE: Two person operation!

10. Using drill, 1/4" drill bit and shop vac, align drill bit tip to scribe/center-punch mark of two outside holes and begin drilling. While drilling, have another person using shop vac to remove debris. Make sure all debris is removed before you proceed any further.

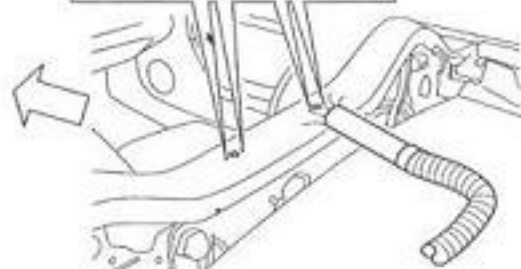
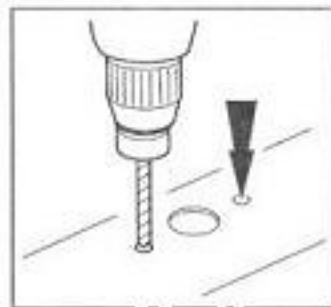

11. Insert rosette(s) into panel. Clip side toward front of vehicle. If clip is not oriented this way, the rosette will not be able to be installed.

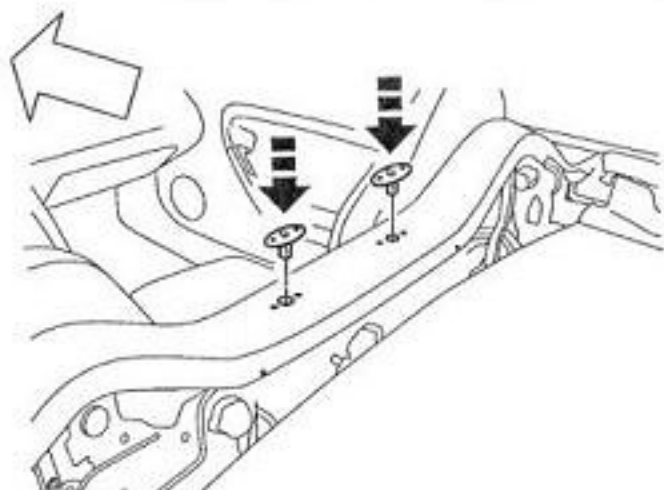

12. a. Install Brackets under panel as shown.

b. Using screws, attach rosette(s) to Brackets, do not fully torque/tighten.

NOTE: Concentrate on attaching the first screw and then align and attach the second screw.

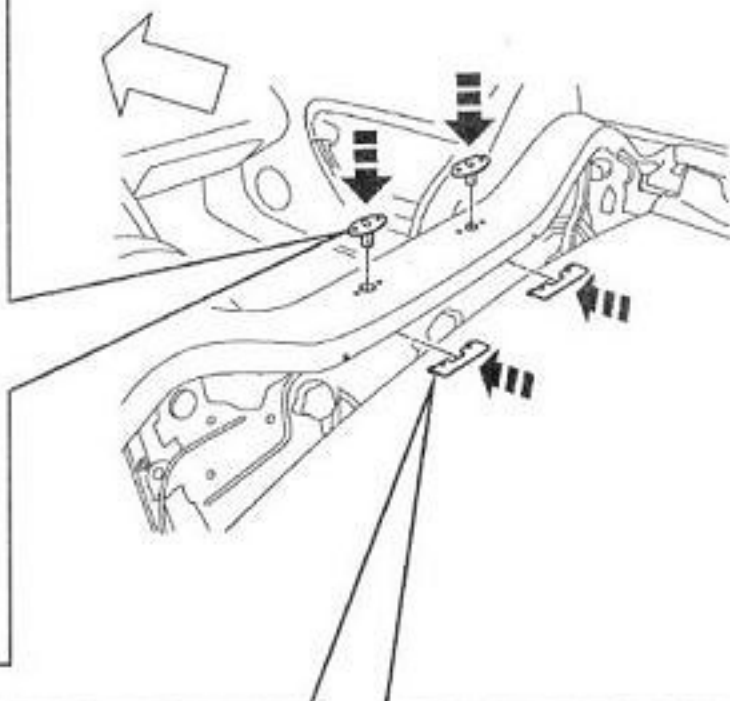
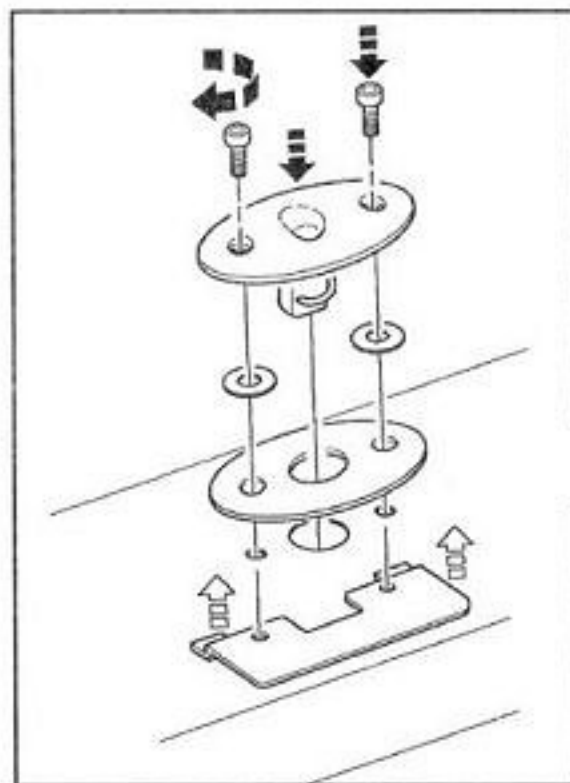

13. a. Install Windstop, angled towards the front of vehicle.
- b. Check for adjustment, if ok, remove Windstop. If not, re-adjust rosette(s) to cross car width then remove Windstop.
- c. Once properly adjusted, tighten screws located in rosette(s) and reinstall Windstop. When properly installed. Windstop should snap down into place.

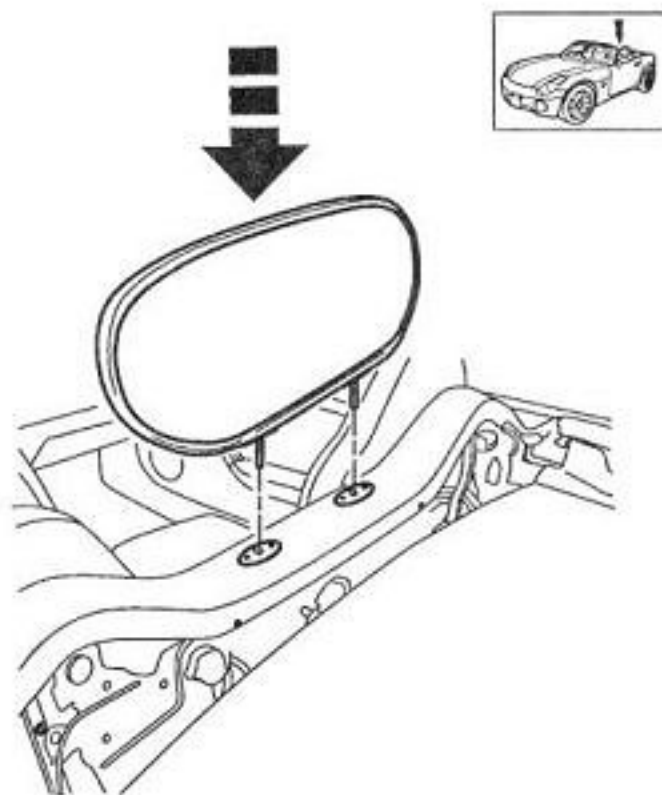

14. When not in use, remove Windstop by bracing one hand along rear of panel between rosette(s) and pulling up on Windstop with other hand.

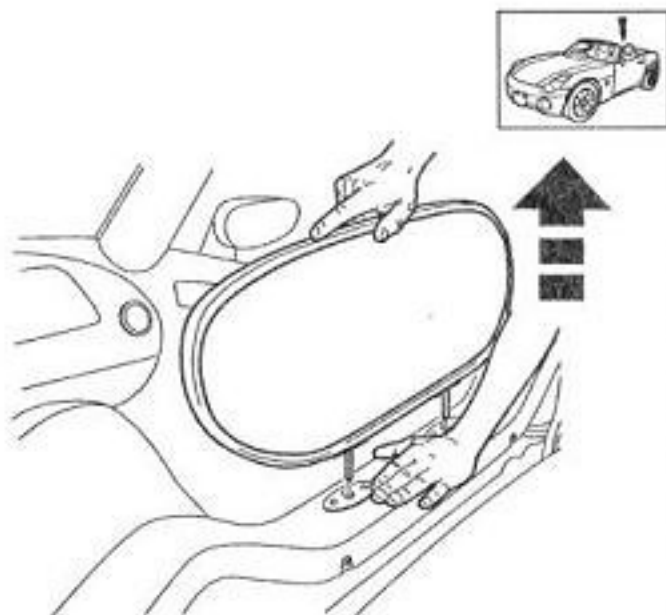

NOTE: This product is compatible with the Tonneau Cover. Cut a small hole in Tonneau Cover where the pins would pass through to the rosette.

Storage

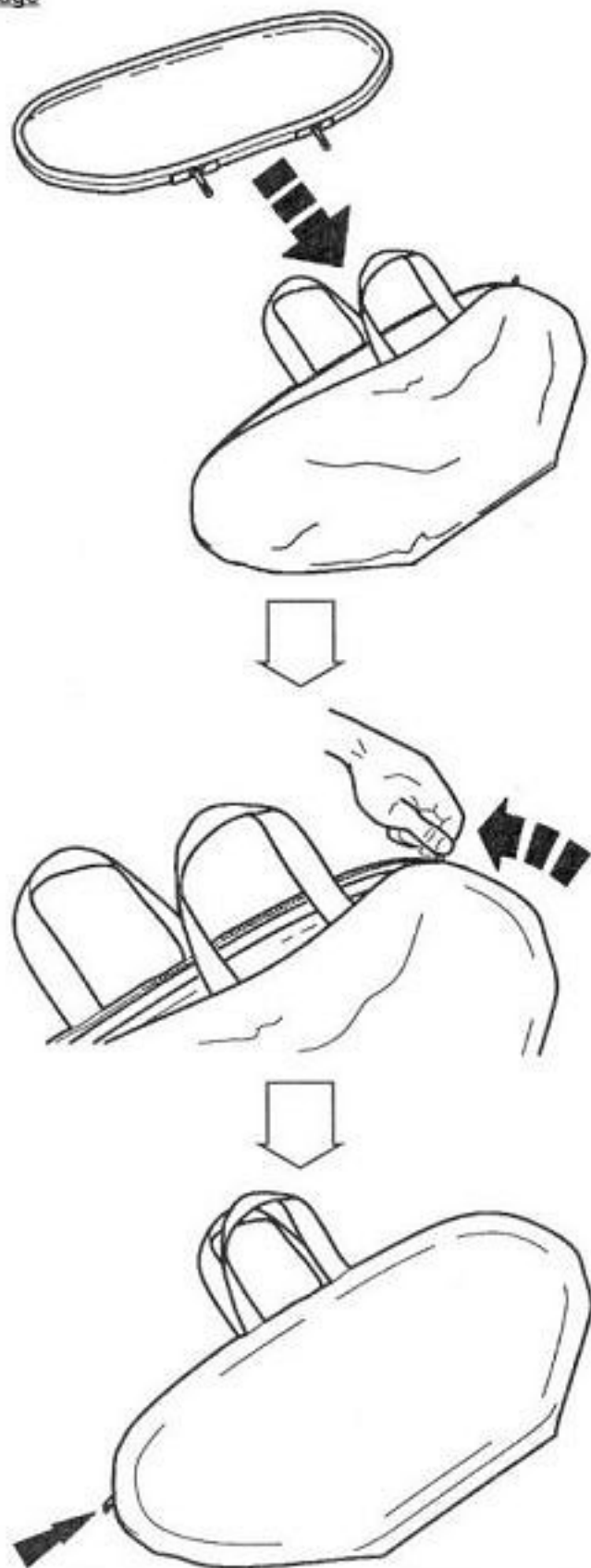

Care & Cleaning

- Always store the wind deflector in the bag when it is not in use
- Please store flat in vehicle trunk when not in use. To avoid damage, do not store or place items on Windscreen when stored.
- Windscreen should not be cleaned with caustic detergents. Clean only with water and a mild cleaner.
- The convertible top can be in the raised position while the windstop is installed.