

Install procedure for the improved noise insulator for the LFN Ecotec engines

To some, the ticky tick buzzzz noise from the fuel delivery system is no big deal. To others, it would be nice if it was not so loud. Evidently, GM also thinks it's a little noisy because they have designed a mod that directly replaces the OEM with this vastly thicker part shown above. GM PN 12628069.



OEM is a cardboard material with a black fuzzy texture similar to speaker cabinets.



So, if you want to reduce this noise by over 50%, it costs less than 10 bucks and less than an hour of your time. Follow these simple steps.

Step 1:

Buy part. Online at [CLICK](#)

Step 2:

Install part.

You need to remove the air inlet. Don't panic, it's not that hard. The only thing not shown here is that you need to remove the windshield wiper arms. Again, no big. Don't disconnect the washer hoses, not necessary. Just move the assembly to a place away from the firewall so you can reach the fuel pump bracket.

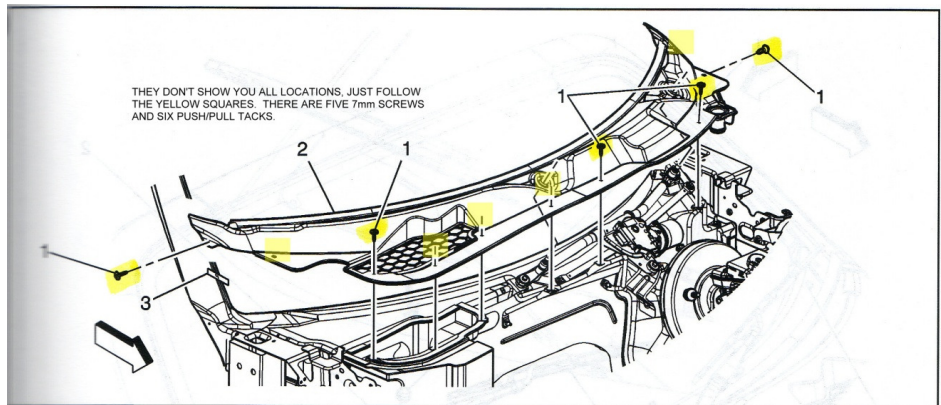

1581459

Air Inlet Grille Panel Replacement (Solstice)

Callout	Component Name
Preliminary Procedure	
Remove the wiper arms. Refer to <i>Windshield Wiper Arm Replacement</i> on page 4-214.	
1	Air Inlet Grille Retainer (Qty: 10)
2	Air Inlet Grille
3	Washer Pump Hose
Tip: Disconnect at the outer edge of the air inlet grille panel.	

Step 3

Remove the three bolts as shown. Take off the old cover and replace with the new one. Reverse these steps replacing the OEM insulator with the replacement to complete the job.

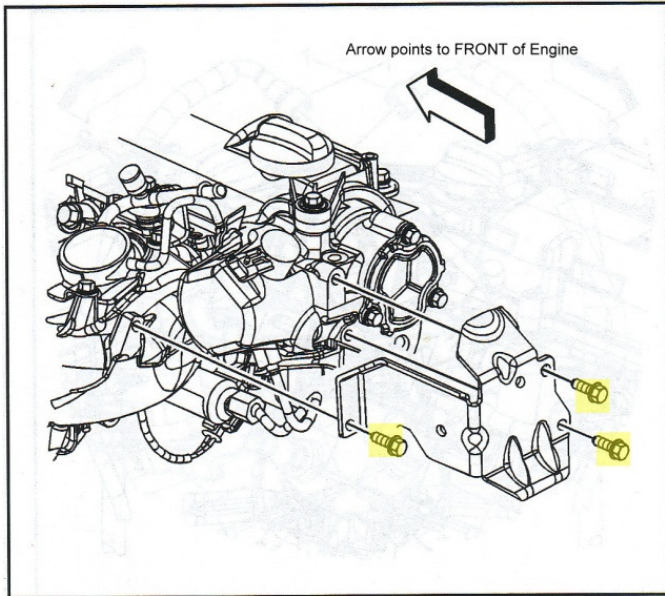

10mm 3 places

Remove the high pressure fuel pump cover bolts.
Remove the high pressure fuel pump cover.

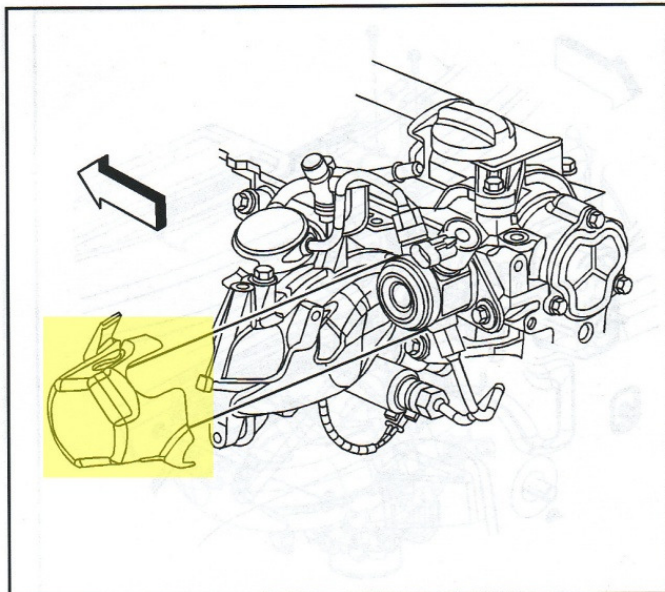

Remove the wire harness from pump (squeeze under and pull)

Cardboard with fuzzy black texture, simply pull off

Remove the high pressure fuel pump insulator.